

INDOOR DISCONNECTOR

Type **XMS**

RAIL VEHICLES

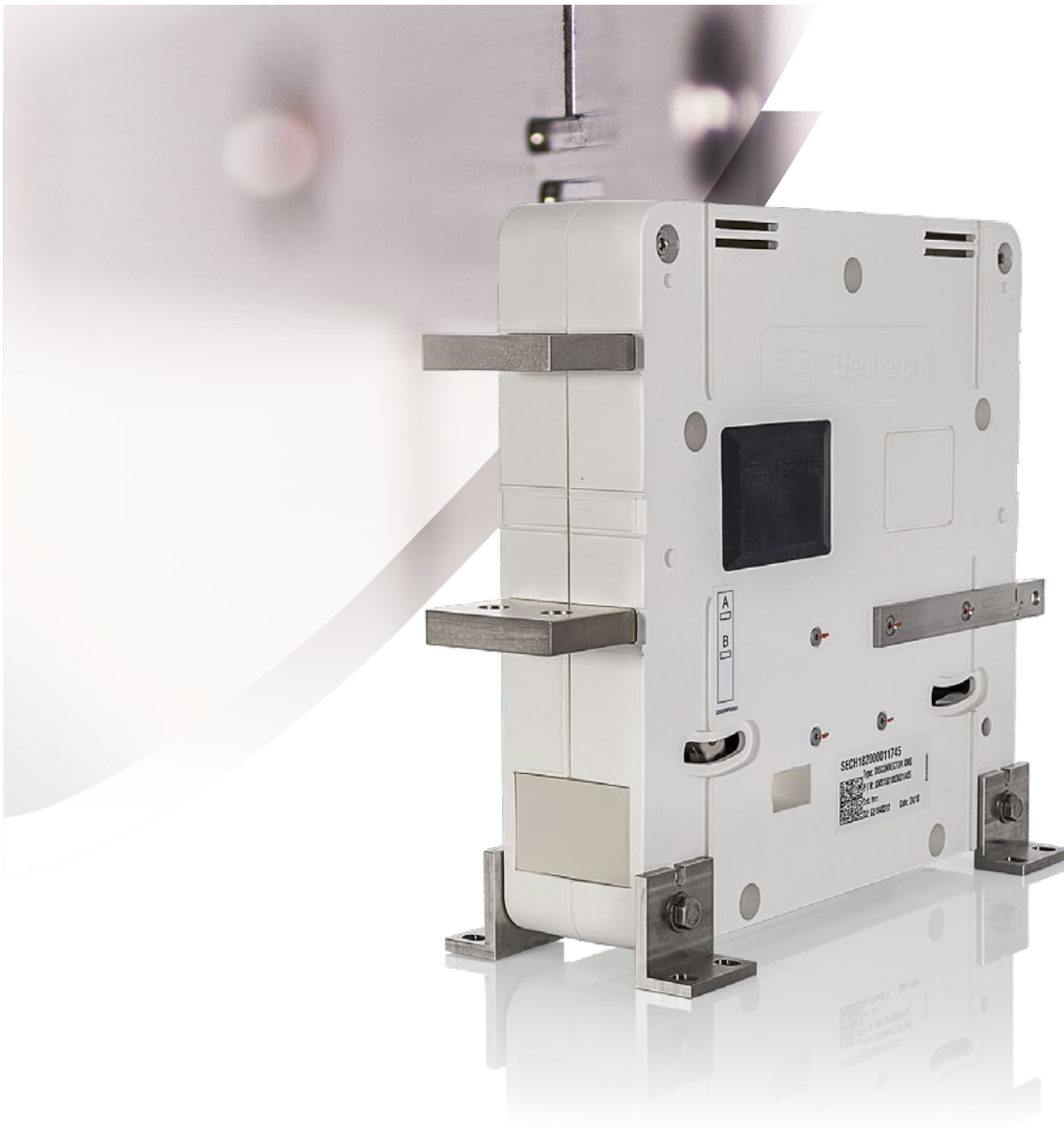

GENERAL INFORMATION

XMS disconnecter is designed to connect and isolate electrical circuits in traction vehicles or in different types of fixed installations. It offers our customers a complementary solution to the use of Sécheron's BMS contactors for rated thermal currents up to 1,500 A and rated voltages up to 4,000 V. The various applications suitable to this device

include the selection of the adapted voltage on the secondary winding of the transformer for dual voltage AC vehicles, as well as the isolation of the main traction inverters for EMUs or Metros. Fitting the XMS with clever technical solutions has enabled Sécheron to develop a device with a high level of performance, combined with the highest reliability.

APPLICATIONS, TYPICAL EXAMPLES

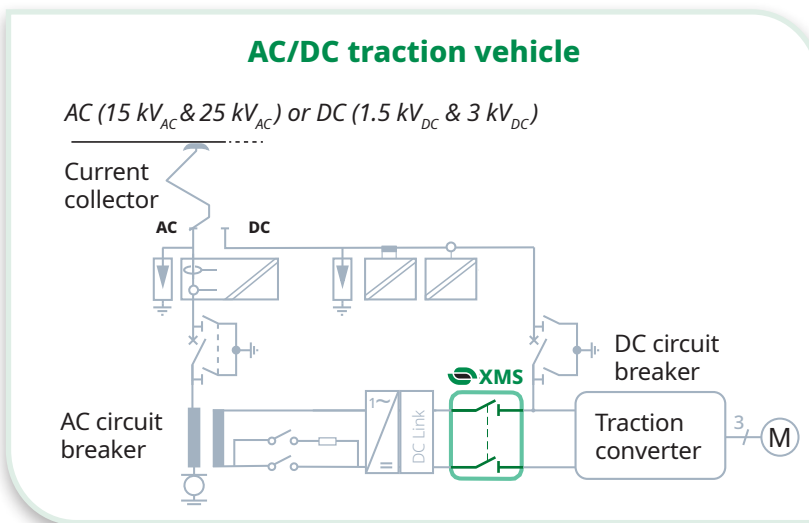

The XMS disconnecter is an off-load switch, mainly used in railway's multi-system locomotives and trains.

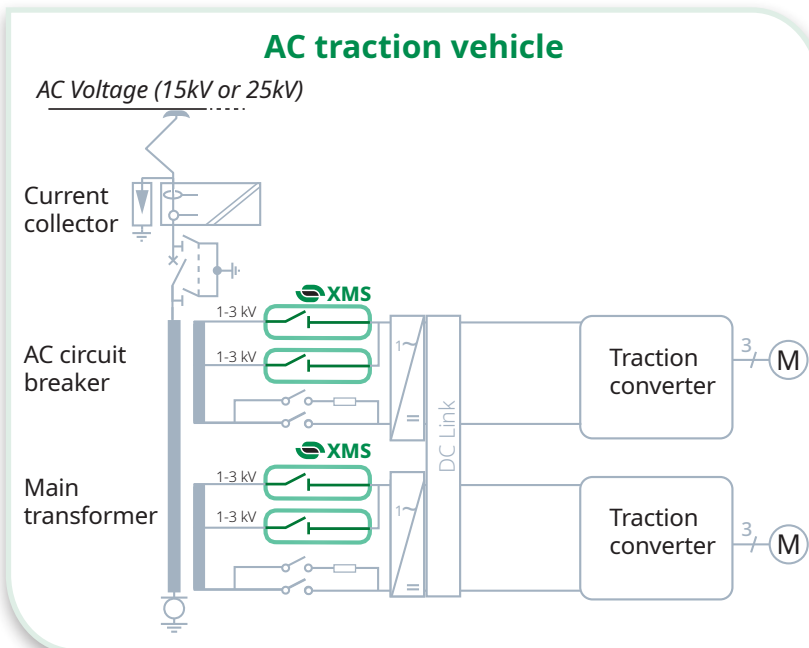

XMS is also used for DC traction power substations and other industrial plants.

MAIN FEATURES

- Rated operational voltage up to 4,000 (V_{AC/DC})
- Rated thermal current 800 A and 1,500 A
- Multi-poles versions up to 3 poles
- Electromagnetic closing and opening
- High overvoltage category, OV3
- High resistance to pollution (degree PD3).
- Complies with standards
EN/IEC 60077-2; EN/IEC 61373; EN 45445

MAIN BENEFITS

- ✓ High insulation level
- ✓ Multipole versions
- ✓ Low clearance requirements around the product
- ✓ High short-time withstand current
- ✓ Bi-stable with simple control circuit
- ✓ Short closing & opening time
- ✓ Extensive factory reliability testing
- ✓ Proven design accepted worldwide
- ✓ Low maintenance & low Total Cost of Ownership (TCO)

SECHERON XMS RANGE

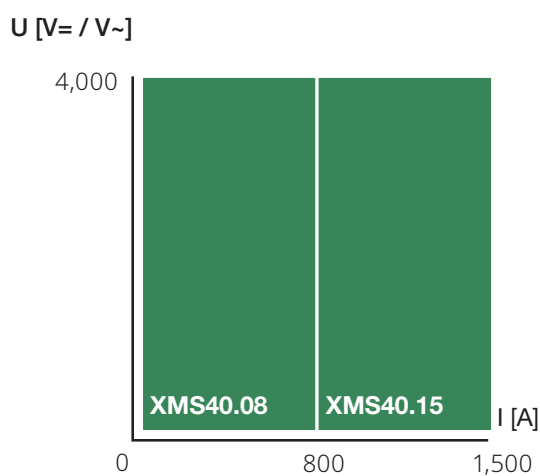

For 2-pole and 3-pole versions, the main contacts are mechanically linked or can be independent as an option.

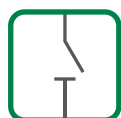

XMS
1 pole



XMS
2 poles



XMS
3 poles

DATA FOR PRODUCT SELECTION

	Symbol	Unit	XMS 40.08	XMS 40.15
MAIN HIGH VOLTAGE CIRCUIT				
Component category			A2	
Type of main contact			Bi-stable	
Number of poles			1 pole, 2 poles and 3 poles	
Rated operational voltage	U_e			
- DC voltage		[V]	4,000	
- AC voltage		[V]	4,000 (up to 400 Hz)	4,000 (50 Hz)
Rated insulation voltage	U_i	[V]		
- Over voltage category OV3			4,000	
- Over voltage category OV2			5,000	
Conventional free air thermal current per pole ⁽¹⁾	I_{th}	[A]	800	1,500
Rated short-time withstand current	$I_{cw/t}$	[kA]/[ms]	60/ 100	
Maximum breaking capacity ⁽²⁾				
- Under 4000 V _{DC}	I_c	[mA]	100	
Maximum making capacity ⁽³⁾				
- Under 100 V _{DC}	I_f	[A]	10	
Rated power-frequency test voltage (50 Hz/1min)	U_{50}	[kV]	12	
Rated impulse withstand voltage (1.2/50 μs)	U_{imp}	[kV]	25	
⁽¹⁾ At $T_{amb} = +40^\circ\text{C}$ for DC and AC (50/60 Hz) voltage. For higher frequency, please contact Sécheron. ⁽²⁾ Maximum seldom breaking capacity. ⁽³⁾ Maximum seldom making capacity.				
LOW VOLTAGE CIRCUIT				
Control circuit				
Nominal supply voltage	U_n	[Vdc]	1 pole	2 poles 3 poles
Range of voltage			24, 36, 48, 72, 84, 110	
Nominal switching power (0.5 s)	P_c	[W]	365	[0.7 - 1.25] U_n
Nominal holding power	P_h	[W]		730 1,095
Mechanical switching time ⁽⁴⁾	t_{cc}	[ms]		0 <100
⁽⁴⁾ At U_n and $T_{amb} = +20^\circ\text{C}$.				
Auxiliary contacts				
Type of contacts			Potential free (PF)	
Rated voltage		[V _{DC}]	24 to 110	
Conventional thermal current	I_{th}	[A]	10	
Utilization category according to EN60947				
- AC-15 230 V _{AC}			1.0 A	
- DC-13 110 V _{DC}			0.5 A	
Minimum let-through current at 24 Vdc ⁽⁵⁾		[mA]	≥ 10 (silver contacts) or 4 ≤ I < 10 (gold contacts)	
⁽⁵⁾ For a dry and clean environment.				
Low voltage interface				
Control circuits			Screw terminal or AMP 18 pins connector	
Insulation				
Rated power-frequency withstand voltage (50 Hz / 1min)				
- LV circuit to earth	U_{50}	[kV]	1.5	
OPERATING CONDITIONS				
Installation			Indoor	
Altitude		[m]	≤ 2,000	
Working ambient temperature	T_{amb}	[°C]	- 40 to + 70	
Humidity			95% at + 40°C	
Pollution degree			PD3	
Minimum mechanical durability	N	Operations	125,000	

PRODUCT INTEGRATION

MAIN DIMENSIONS (STANDARD VERSION)

HV connections	M11 screws (..08), M14 (..15)
Earth connections	M8 screws
LV Connections	Screws terminal
Fixing points	M8 screws

Dimensions without tolerances are indicative. All dimensions are in mm. The maximum allowed flatness deviation of the support frame is 0.5 mm.

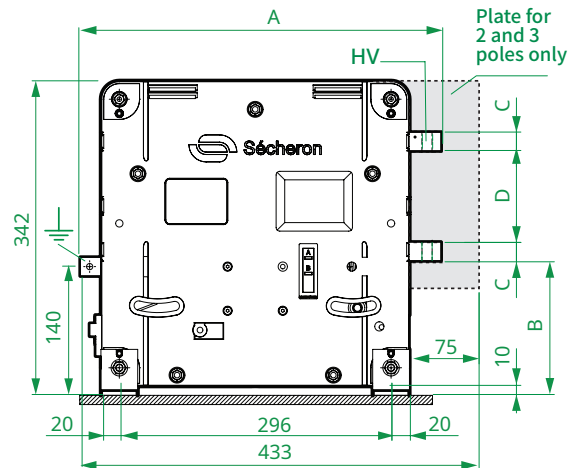

XMS40.08

Horizontal/vertical installation

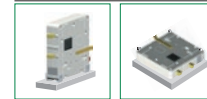

Dimensions [mm]	XMS40.08	XMS40.15
A	392	412
B	146	151
C	20	15
D	100	102
Weight per pole	10 kg	13 kg

OPTIONAL INWARDS FIXATION AVAILABLE

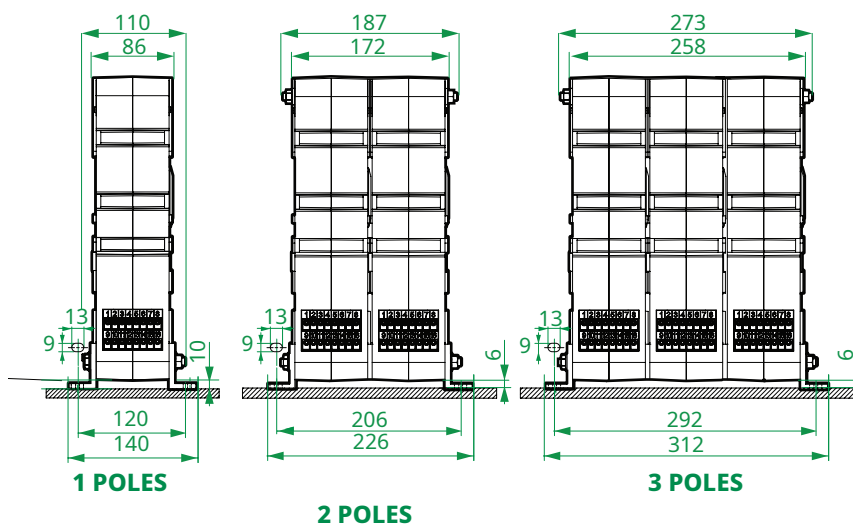

AVAILABLE XMS CONFIGURATION

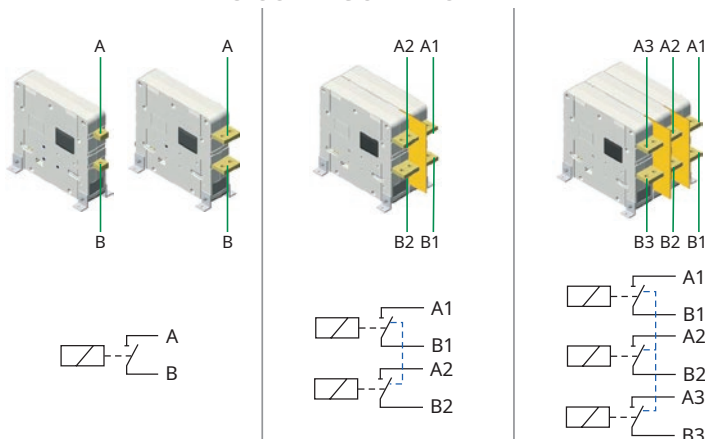

The multipole versions are delivered with the poles mechanically connected.

It is however also possible to get multipole version with independent poles (shown on page 7).

CONTROL AND LOW VOLTAGE WIRING DIAGRAM

LOW VOLTAGE WIRING DIAGRAM (Screw terminal)

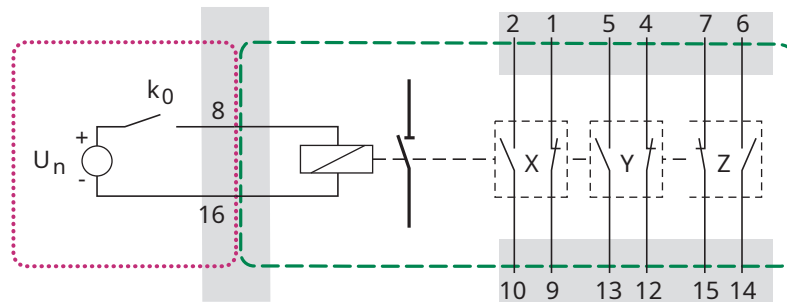

Legend of the schemes:

- XMS disconnector main contact
- 1a+1b - Switch PF
- XMS closing coil
- Screw terminal
- Sécheron's scope
- Customer's scope

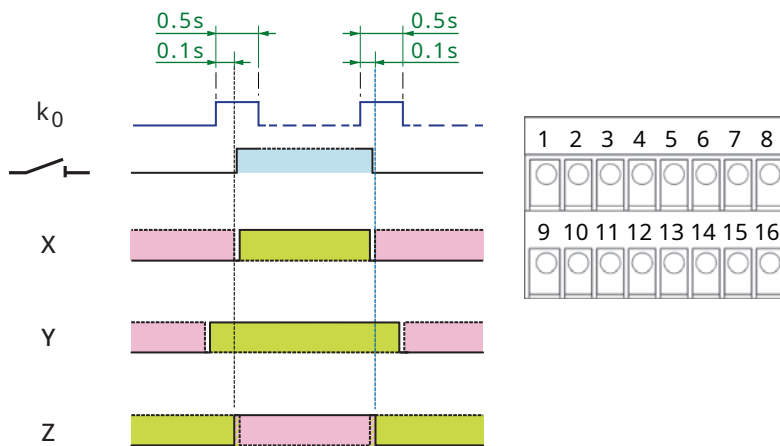

OPTIONS

(SUBJECT TO ADDITIONAL COSTS)

SMALL HEIGHT VERSION

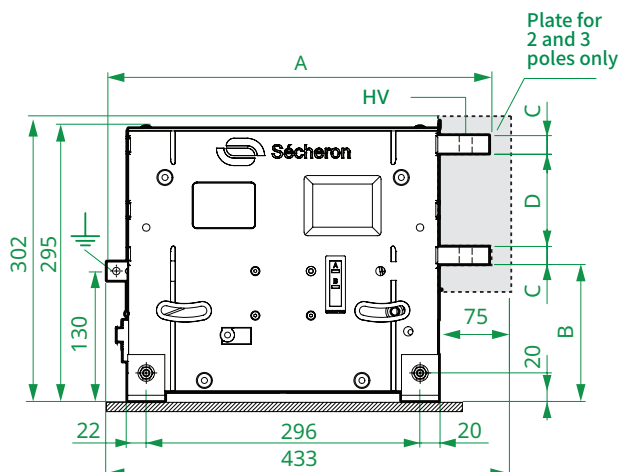

XMS40.08S XMS40.15S

Horizontal/vertical installation

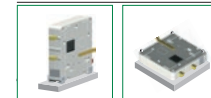

Dimensions [mm]	XMS40.08	XMS40.15
A	392	412
B	146	151
C	20	15
D	100	102
Weight per pole	10 kg	13 kg

SMALL HEIGHT VERSION

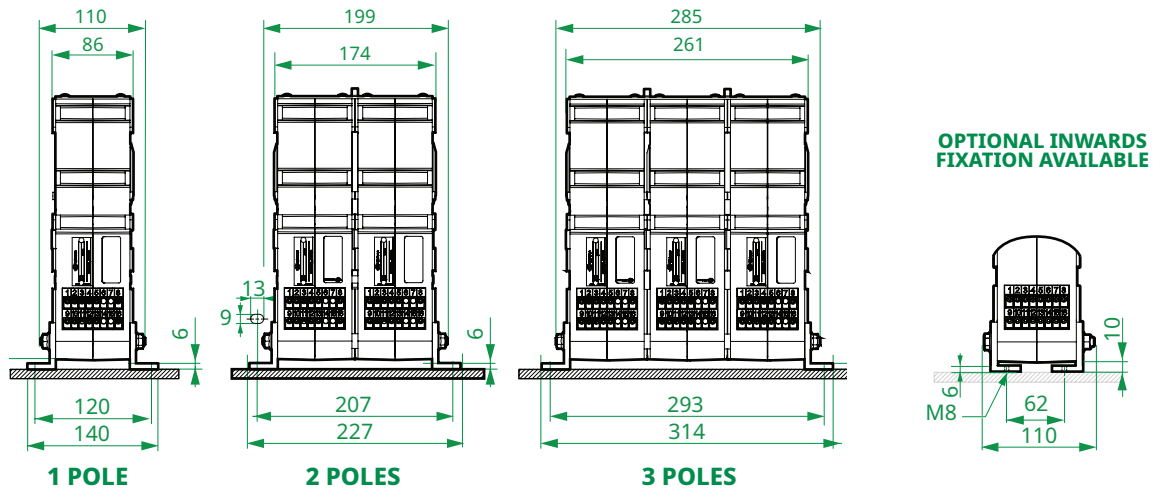

LOW VOLTAGE AMP CONNECTOR

LOW VOLTAGE WIRING DIAGRAM

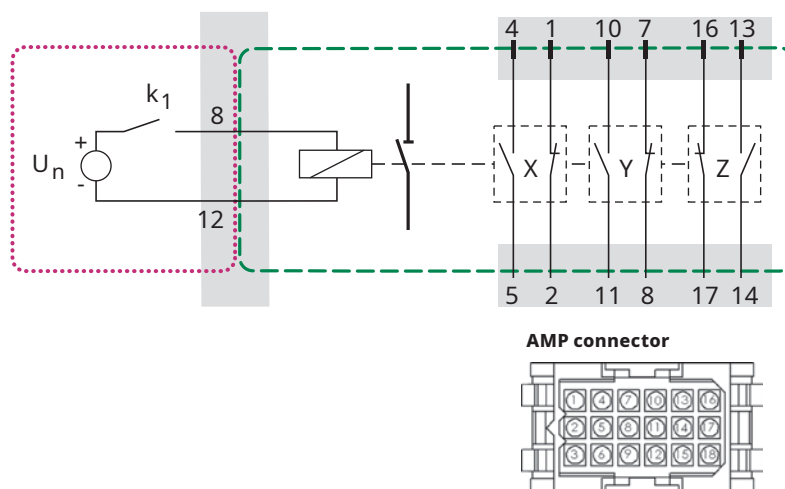

Legend of the schemes:

- XMS disconnector main contact
- 1a+1b - Switch PF
- XMS closing coil
- AMP connector
- Sécheron's scope
- Customer's scope

MOBILE CONNECTORS

Mobile connectors	
Type	Secheron's number
AMP connector 18 pins for 0.5 mm ²	SG201013R1
AMP connector 18 pins for 1.5 mm ²	SG201013R2

The low voltage AMP mobile connector can be ordered separately.

MULTIPOLE VERSION WITH INDEPENDENT POLES

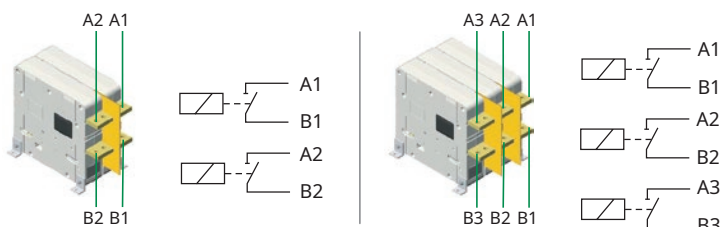

The multipole versions are delivered with the poles mechanically connected.

It is however also possible to get multipole version with independent poles as shown beside.

DESIGNATION CODE FOR ORDERING

- Be sure to establish the designation code from the latest version of our brochure by downloading it from the website: www.secheron.com.
- Be careful to write down the complete alphanumeric designation code with 18 characters when placing your order.
- For technical reasons some variants and options indicated in the designation code might not be combined.
- For other configurations not described in the brochure, please contact Sécheron.

Example of customer's choice:	XMS	40	15	0	2	L	110	2	0	A	0	1
Line:	10	11	12	13	14	15	16	17	18	19	20	21

The bold part of this designation code defines the device type, and the complete designation defines the identification number of the product, as displayed on the identification plate attached to the product.

DESIGNATION CODE

Line	Description	Designation	Standard	Options	Customer's choice
10	Product type	XMS	XMS		XMS
11	Rated operational voltage	4,000 V _{AC}	40		40
12	Rated conventional free air thermal current	800 A 1,500 A	08 15		
13	Height	Standard (342 mm) Small (295 mm)	0	S	
14	Number of poles	1 pole 2 poles 3 poles	1 2 3		
15	Mechanical link between poles	Yes No	L	0	
16	Nominal supply voltage	24 V _{DC} 36 V _{DC} 48 V _{DC} 72 V _{DC} 84 V _{DC} 110 V _{DC}	024 036 048 072 084 110		
17	Auxiliary contacts (per pole) ⁽¹⁾	2a + 2b - (switch PF) - silver type 2a + 2b - (switch PF) - gold type 2a + 2b - (switch PF) - silver type 2a + 2b - (switch PF) - gold type 3a + 3b - (switch PF) - silver type 3a + 3b - (switch PF) - gold type	1X+1Y 1X+1Y 2X 2X 2X+1Z 2X+1Z	2 D 1 E 4 G	
18	Low voltage interface	Screw terminal AMP 18 pins connector	0	1	
19	Fixing angle position	4 bottom-outwards 4 bottom-inwards	A	B	
20	Spare digit		0		0
21	Spare digit		0		0

⁽¹⁾ Other configuration on request.

The low voltage mobile connector must be ordered separately (refer to the table page 7).

AMP mobile connector: SG201013R1 SG201013R2



Sécheron SA
Rue du Pré-Bouvier 25
1242 Satigny - Geneva
CH-Switzerland

www.secheron.com
Tel: +41 22 739 41 11
Fax: +41 22 739 48 11
ess@secheron.com